

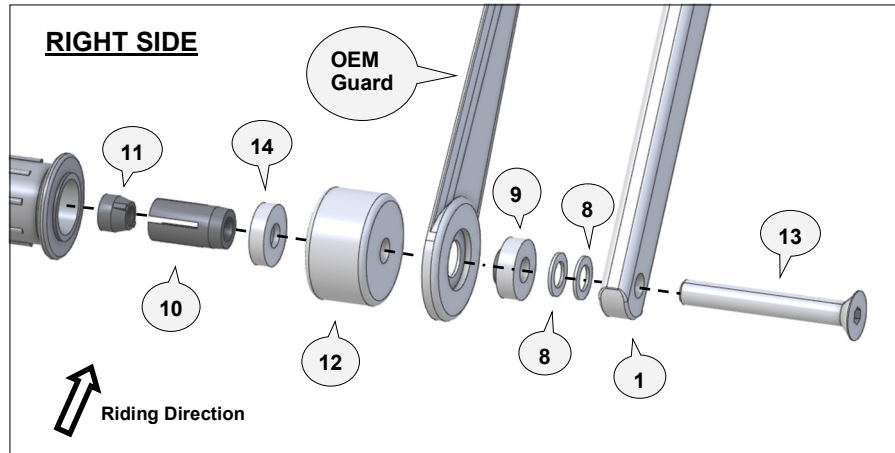

www.barkbusters.net

FITTING INSTRUCTIONS for...

- DUCATI Multistrada V2/V2S (2022 on)
(mounted in conjunction with original DUCATI plastic handguard)



Preparation:

- Loosen Original Ducati handguard bolt from end of handlebar, approximately 2 turns.
- Slightly pull the bolt out of the handlebar until the second brass internal part can be grabbed (the brass expander is in 2 pieces, make sure to grab the deepest part).
- While holding the brass parts, fully unscrew the bolt out of the assembly.
- Remove the black bar end weight and the brass expander (2 pieces).

Note:

Barkbusters Handguard and Lever Protector is to be mounted in conjunction with original Ducati plastic handguards.
When mounted correctly, make sure the indicator is not fully obstructed.

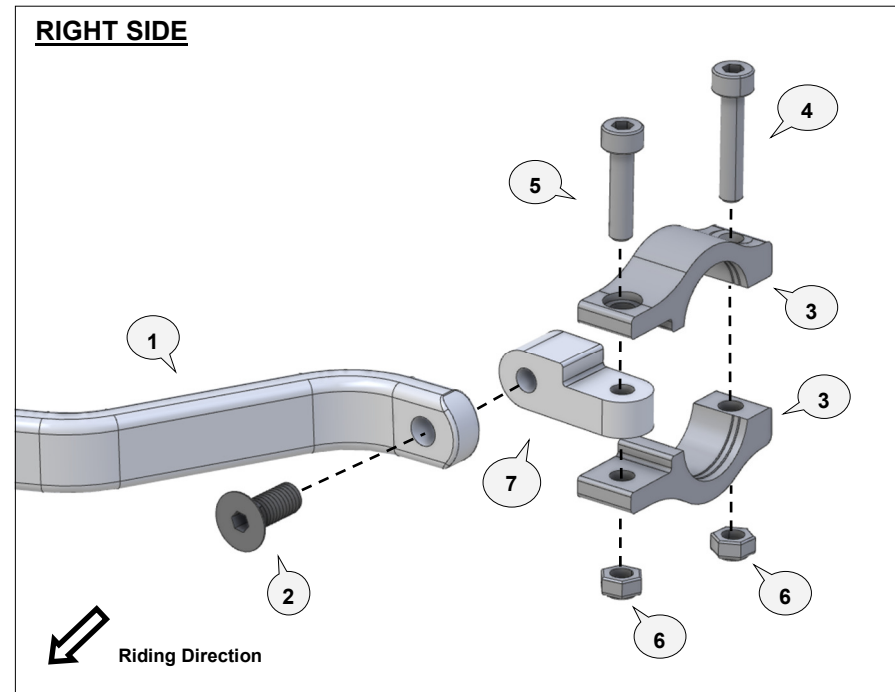

Important Fitting Procedure

Installation is shown for the right side. Repeat for left side with applicable parts.
Loosely fit the clamp parts to the tapered section of handlebar (see diagram).

Note: The rings machined on the inside of the clamp surface identify the larger section of the clamp. Rings must be positioned toward the larger section of the handlebar or centre of the motorbike.

Important: Rings on the top and bottom clamp halves, must align with each other.

- Attach bar end parts as per diagram to the backbone and original plastic handguard.
- Insert into handlebar end. Do not tighten at this stage.
- Attach inner end of backbone to clamp connector (7) with bolt (2).
- Tighten the bar end bolt (13) lightly.
- Position the backbone so it clears the tank by at least 10mm when the steering is at full lock.

Tighten all bolts in the following order using recommended torque specifications over page.

Tighten bolt (13) into the handlebar end.

Tighten bolt (2) through the aluminium bar (1) to the clamp connector (7) of the clamp assembly.

Tighten bolt (5) to solidly lock the clamp connector (7) between the clamp saddles (3).

Tighten bolt (4) to secure the clamp assembly firmly to the handlebar. The gap between the 2 saddle should be even, front and back.

Note: The clamp is designed to allow the nut on bolt (5) to pull into the recessed hole. This eliminates the need for a wrench after the bolt starts to tighten.



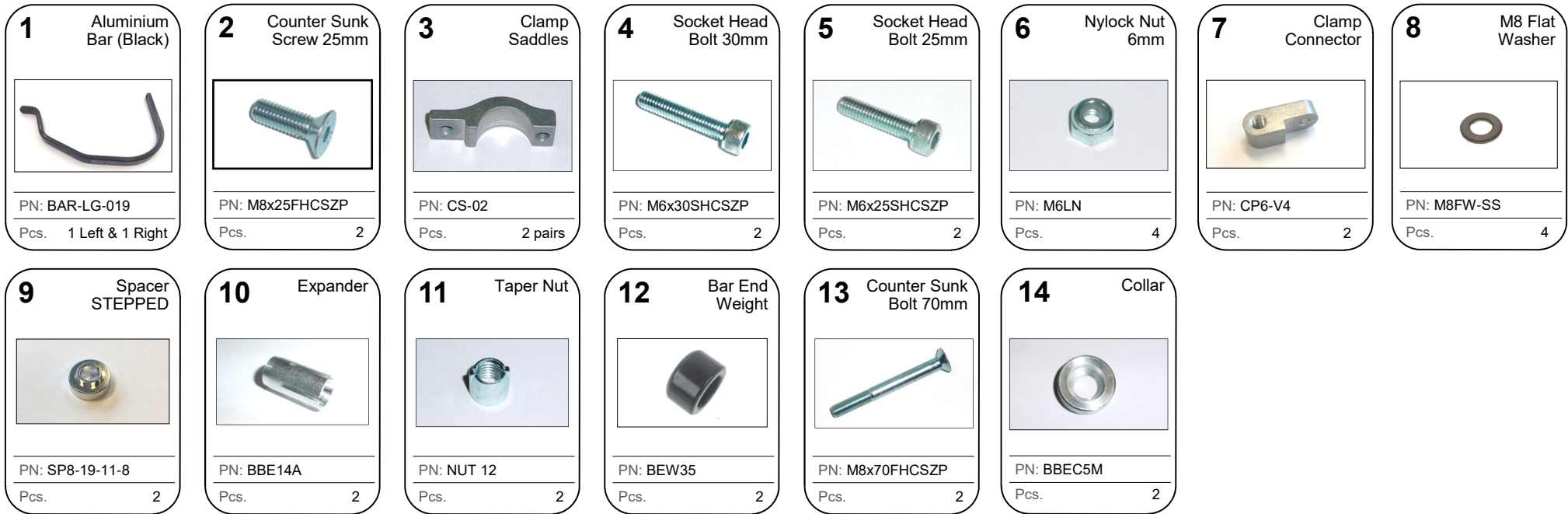

CAUTION:

Installation of the handguard is safety-relevant work and can be complicated. We recommend the installation be performed by a motorcycle service technician. Rideworx accepts no liability for damages caused by improper mounting. All screws, bolts and nuts, including all replacement hardware provided by Rideworx, should be tightened to the torque specified in the table. After the first 50km of riding check all screws, bolts and nuts are tightened to the correct torque. We recommend a medium strength liquid thread lock product on all fasteners.

Recommended Torque Settings	
M6	10 Nm (7.4 lbf ft)
M8	28 Nm (20.7 lbf ft)

WARNING:

Check operation of all handlebar controls, specifically the throttle, front brake, kill switch and clutch to ensure they are operating correctly and are in accordance with the OEM specifications. Do not ride the motorcycle if any controls are not operating correctly. Check periodically that all bolts are tight.



Email: info@barkbusters.net
Web: www.barkbusters.net



Disclaimer:

A failure to follow these fitting instructions could cause serious injury, death or property damage. These handguards are intended solely for use with motorcycles/ATV/snowmobiles/scooters that have not been modified. They are not designed to prevent injury or death while riding or in an accident or crash. The user must ensure that all controls are free of the handguards every time that they ride. By installing and/or using this product you acknowledge that you accept these terms and have followed the fitting instructions.