



www.barkbusters.net

# FITTING INSTRUCTIONS for...

- KAWASAKI KLZ1000 Versys ('19 on)

## Preparation

Remove original handguards and bar end weights if fitted.

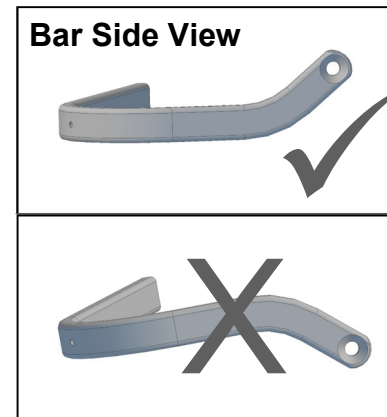
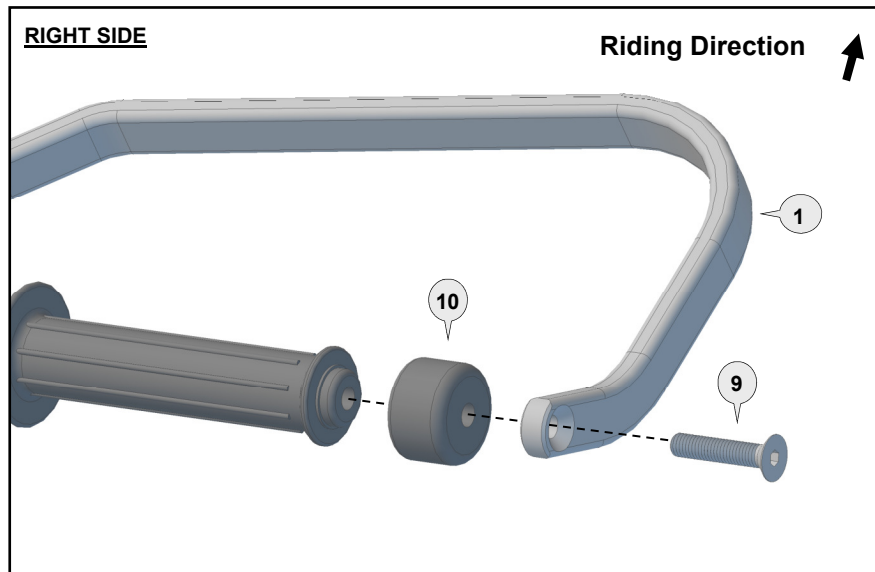
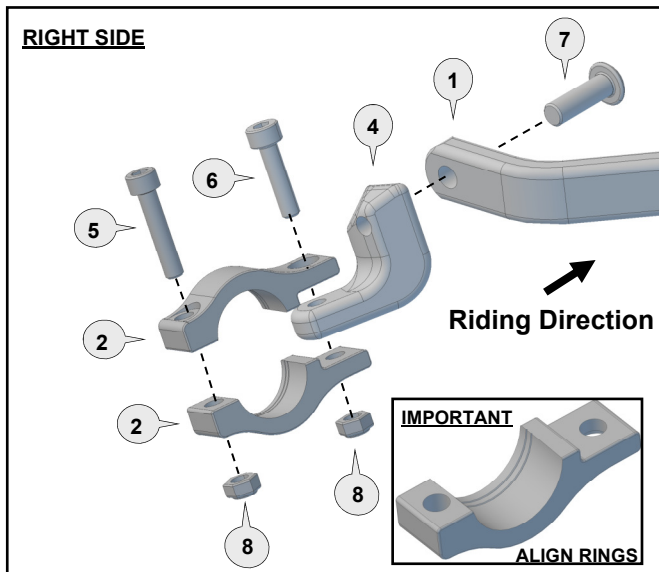

### Fitting Procedure shown for the Right side (repeat for left side with applicable parts)

**IMPORTANT:** There are rings machined into the inside of the tapered clamp surface to assist with a correct fit. The rings on both halves of the clamp should line up with each other and be positioned towards the centre of the motorcycle on the left and right side.

Loosely assemble clamp to handlebar as per diagram.

Attach the handguard backbone with applicable parts to the handlebar end and also to the clamp connector (4) as per diagrams.

**Note:** The preferred backbone position is horizontal when viewed from the side.

Tighten all bolts in the following order using recommended torque specifications over page.

**Tighten bolt (9)** into the handlebar end.

**Tighten bolt (7)** through the aluminium bar (1) to the clamp connector (4 or 3) of the clamp assembly.

**Tighten bolt (6)** to solidly lock the clamp connector (4 or 3) between the clamp saddles (2).

**Tighten bolt (8)** to secure the clamp assembly firmly to the handlebar.

**Note:** The clamp is designed to allow the nut on bolt (6) to pull into the recessed hole. This eliminates the need for a wrench after the bolt starts to tighten.









### Personalise Your Protection

Guard options sold separately

<b>JET</b>	JET-003
<b>VPS</b>	VPS-003
<b>Storm</b>	STM-003
<b>CARBON</b>	BCF-003

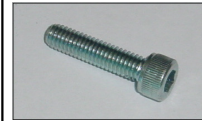

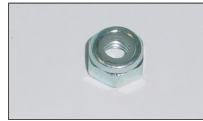
Phone: +61 (0)2 4271 8244  
Email: info@barkbusters.net

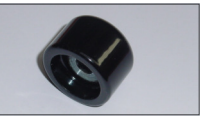
<p><b>1</b> Aluminium Bar</p>  <p>PN: BAR-V-042 Pcs. 1 Left &amp; 1 Right</p>	<p><b>2</b> Clamp Saddle</p>  <p>PN: CS-02 Pcs. 2 pairs</p>	<p><b>3</b> Connector Left</p>  <p>PN: CP8-L Pcs. 1</p>	<p><b>4</b> Connector Right</p>  <p>PN: CP8-R Pcs. 1</p>	<p><b>5</b> Socket Head Bolt 30mm</p>  <p>PN: M6x30SHCSZP Pcs. 2</p>	<p><b>6</b> Socket Head Bolt 25mm</p>  <p>PN: M6x25SHCSZP Pcs. 2</p>	<p><b>7</b> Button Head Bolt 35mm</p>  <p>PN: M8x35BHCSZP Pcs. 2</p>	<p><b>8</b> Nylock Nut 6mm</p>  <p>PN: M6LN Pcs. 4</p>
<p><b>9</b> Flat Head Bolt 35mm</p>  <p>PN: M8x35FHCSZP Pcs. 2</p>	<p><b>10</b> Bar End Weight</p>  <p>PN: BEW-35 Pcs. 2</p>						

Recommended Torque Settings	
M6	10 Nm (7.4 lbf ft)
M8	28 Nm (20.7 lbf ft)

**CAUTION:**

Installation of the handguard is safety-relevant work and can be complicated. We recommend the installation be performed by a motorcycle service technician. Rideworx accepts no liability for damages caused by improper mounting. All screws, bolts and nuts, including all replacement hardware provided by Rideworx, should be tightened to the torque specified in the table. After the first 50km of riding check all screws, bolts and nuts are tightened to the correct torque. We recommend a medium strength liquid thread lock product on all fasteners.

**WARNING:**

It is important there is a working clearance (approx 3mm) between the throttle grip end and the handguard to ensure a free closing throttle. Check operation of all handlebar controls, specifically the throttle, front brake, kill switch and clutch to ensure they are operating correctly and are in accordance with the OEM specifications. Do not ride the motorcycle if any controls are not operating correctly. Check periodically that all bolts are tight.



Phone: +61 (0)2 4271 8244  
Email: info@barkbusters.net  
Web: www.barkbusters.net



**Disclaimer:**

A failure to follow these fitting instructions could cause serious injury, death or property damage. These handguards are intended solely for use with motorcycles/ATV/snowmobiles/scooters that have not been modified. They are not designed to prevent injury or death while riding or in an accident or crash. The user must ensure that all controls are free of the handguards every time that they ride. By installing and/or using this product you acknowledge that you accept these terms and have followed the fitting instructions.