



FITTING INSTRUCTIONS for...

- BMW G310 GS (2017 on)
- BMW G310 R (2016 on)

Preparation: Remove original handlebar end bolts and retain weights.

Installation LEFT: G 310R & G 310GS

- Loosely assemble the clamp to the handlebar with clamp connector (5) as per *Diagram 1*.
- Attach handguard backbone (1) with applicable parts to the handlebar end (including Original Bar Weight) as per *Diagram 4* and also to the clamp connector (5) as per *Diagram 1*.
- Position backbone so it is horizontal when viewed from the side and tighten all bolts in the following order: (10), (8), (7) then (6).

Important: Use the specified torque setting over page.

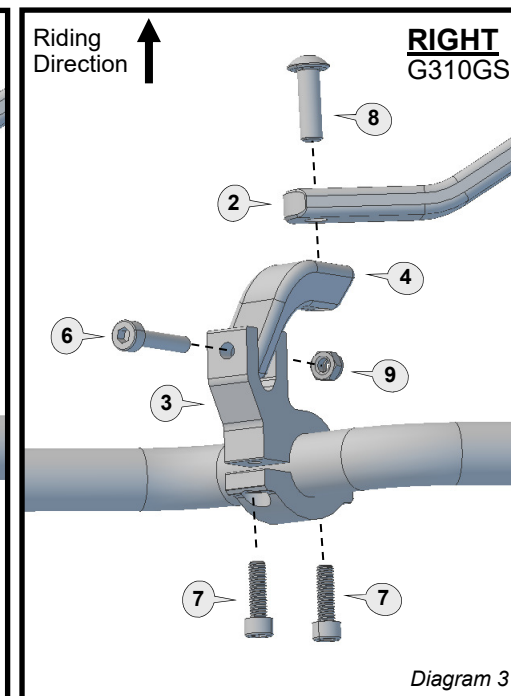
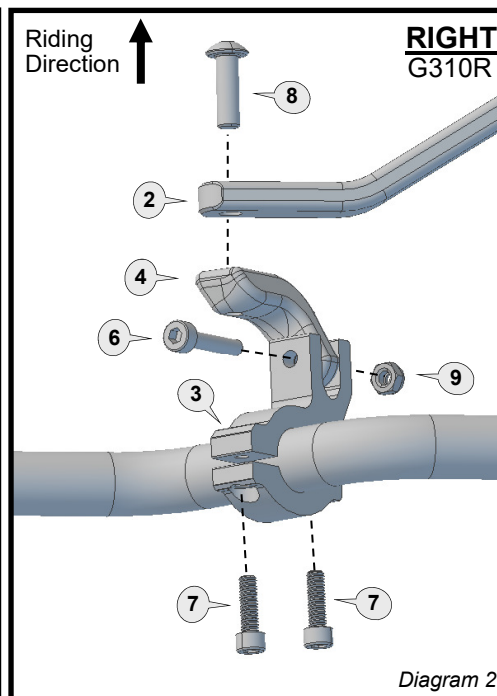
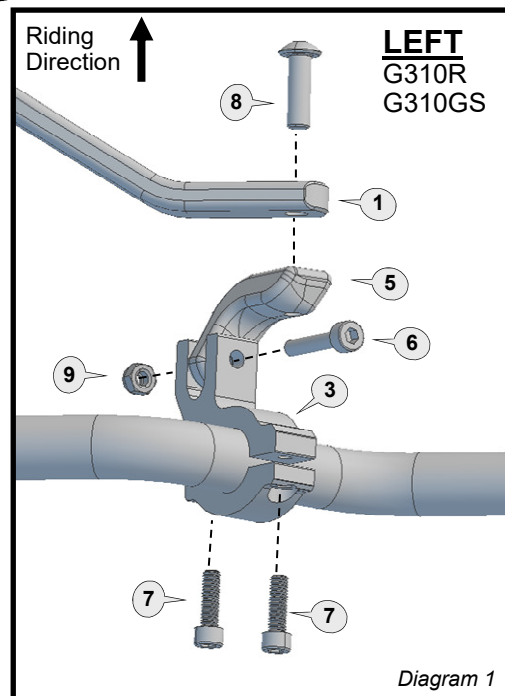

Installation RIGHT: G 310R & G 310GS

- Loosely assemble the clamp to the handlebar with clamp connector (4).
G 310R refer to *Diagram 2*.
G 310GS refer to *Diagram 3*. **Note:** the clamp assembly must be inverted so cables are under the clamp.
- Attach handguard backbone (2) with applicable parts to the handlebar end (including Original Bar Weight) as per *Diagram 4* and also to the clamp connector (4) as per *Diagrams 2 or 3*.
- Position backbone so it is horizontal when viewed from the side and tighten all bolts in the following order: (10), (8), (7) then (6).

Important: Use the specified torque setting over page.

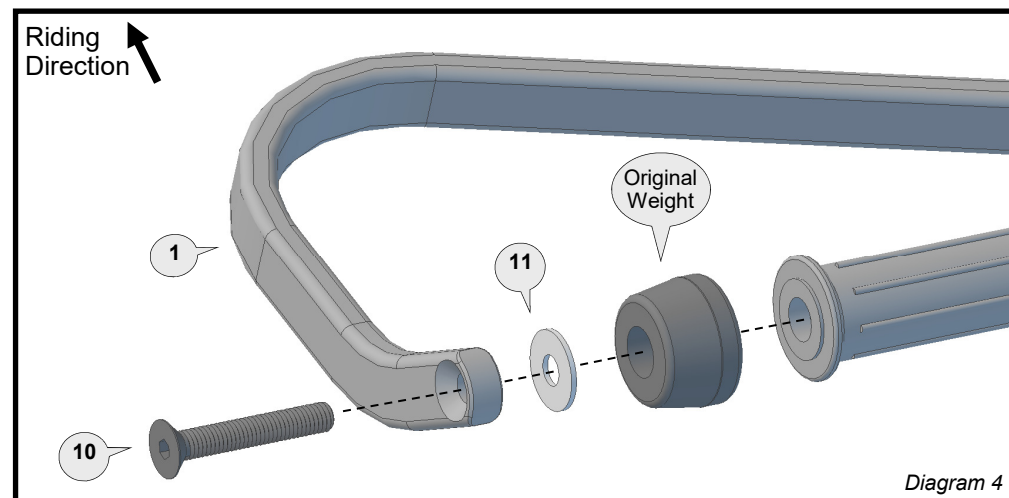

www.barkbusters.net

1 Aluminium Bar (left)

PN: BAR-V-053-L
Pcs. 1

2 Aluminium Bar (right)

PN: BAR-V-053-R
Pcs. 1

3 Multi Fit Clamp 22mm

PN: MFC-22
Pcs. 2

4 Clamp Connector

PN: CP8-L
Pcs. 1

5 Clamp Connector

PN: CP8-R
Pcs. 1

6 Socket Head Bolt 30mm

PN: M6x30SHCSZP
Pcs. 2

7 Socket Head Bolt 20mm

PN: M6x20SHCSZP
Pcs. 4

8 Button Head Bolt 25mm

PN: M8x25BHCSZP
Pcs. 2

9 Taper Nut

PN: M6LN
Pcs. 2

10 Flat Head Bolt 65mm

PN: M8x65FHCSZP
Pcs. 2

11 M8 Washer

PN: M8FW-SS-24
Pcs. 2

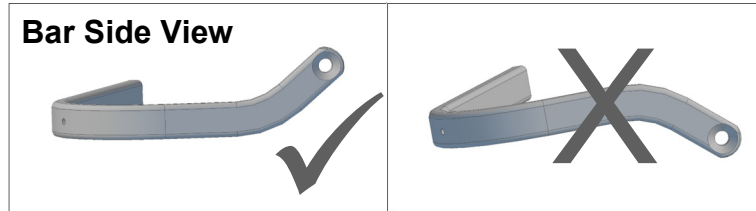

Personalise Your Protection
Guard options sold separately

JET	JET-003
VPS	VPS-003
Storm	STM-003
CARBON	BCF-003

Recommended Torque Settings	
M6	10 Nm (7.4 lbf ft)
M8	28 Nm (20.7 lbf ft)

CAUTION:

Installation of the handguard is safety-relevant work and can be complicated. We recommend the installation be performed by a motorcycle service technician. Rideworx accepts no liability for damages caused by improper mounting. All screws, bolts and nuts, including all replacement hardware provided by Rideworx, should be tightened to the torque specified in the below table. After the first 50km of riding check all screws, bolts and nuts are tightened to the correct torque. We recommend a medium strength liquid thread lock product on all fasteners.

WARNING:

It is important there is a working clearance (approx 3mm) between the throttle grip end and the handguard to ensure a free closing throttle. Check operation of all handlebar controls, specifically the throttle, front brake, kill switch and clutch to ensure they are operating correctly and are in accordance with the OEM specifications. Do not ride the motorcycle if any controls are not operating correctly. Check periodically that all bolts are tight.



Phone: +61 (0)2 4271 8244
Email: info@barkbusters.net
Web: www.barkbusters.net



Disclaimer:

A failure to follow these fitting instructions could cause serious injury, death or property damage. These handguards are intended solely for use with motorcycles/ATV/snowmobiles/scooters that have not been modified. They are not designed to prevent injury or death while riding or in an accident or crash. The user must ensure that all controls are free of the handguards every time that they ride. By installing and/or using this product you acknowledge that you accept these terms and have followed the fitting instructions.